



VENINI

ARTGLASS

Made in Italy



PETER MARINO

Peter Marino è nato a New York nell' agosto del 1949. Dopo aver iniziato gli studi dedicati alla pittura, alla scultura e alla storia dell'arte, Peter Marino ha conseguito il titolo di Architettura, Arte e Pianificazione presso il Cornell University's College of Architecture. Marino nel 1978 ha fondato a New York l'omonimo Studio di Architettura. Peter Marino è conosciuto come l'Architetto per eccellenza dei Brand del lusso, ricevendo molti premi in progetti residenziali, spazi commerciali, culturali e luoghi pubblici in tutto il mondo. Peter Marino è noto per aver inserito oltre 300 opere d'arte contemporanee nei suoi progetti architettonici. Inoltre come artista, possiede una collezione d'arte moderna unica. La sua visione artistica lo ha portato a creare una serie di opere uniche tra cui una collezione limitata di scatole in bronzo.

Peter Marino was born in New York City in August of 1949. Having begun his studies focused on painting, sculpture and art history, Marino went on to earn an architecture degree from Cornell University's College of Architecture, Art and Planning. Marino founded his eponymous, New York-based architecture firm in 1978 and is regarded as the go-to architect for the highest echelons of luxury design, with award-winning residential, retail, cultural, and hospitality projects worldwide. As an architect, Marino is known for integrating art commissions into his architectural designs, with more than 300 site-specific contemporary works living within his designs. As a collector, Marino is known for his carefully curated modern and contemporary art collection. And as an artist in his own right, Marino is known for lending his own unique artistic vision to the invention of various forms, including a limited edition series of cultural bronze boxes.



ARTLIGHT



TOTEM LUCE

design Peter Marino - 2022

TOTEM, una linea che enfatizza la potenza evocativa delle decorazioni tribali in un oggetto scultoreo.

L'opera è frutto della combinazione tra la solidità di una base in marmo nero Zimbabwe eleganti elementi in vetro soffiato dalle forme morbide e dai rimandi organici. Un tributo alla natura impreziosito da lavorazioni a caldo con la foglia d'argento, d'oro e di superfici dall'effetto iridato. La scultura Luminosa, in edizione limitata, è disponibile in due misure ed è proposta anche nella versione senza illuminazione.

TOTEM, collection that emphasizes the evocative power of tribal decorations on a sculptural object.

The work is the result of the combination of the solidity of a black Zimbabwe marble base and elegant blown glass elements with soft shapes and organic references. A tribute to nature embellished with hot handmade technique with silver and gold leaf and surfaces with iridescent effect.

The Luminous sculpture, in limited edition, is available in two sizes and also proposed without lighting.

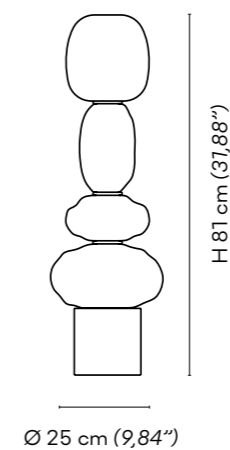

893.85

25 x H 81 cm
4 elementi/ elements
(9,84" - 31,88")

Base: Zimbabwe marmo/ marble

LED

EDIZIONE LIMITATA 8 + 4
LIMITED EDITION 8 + 4

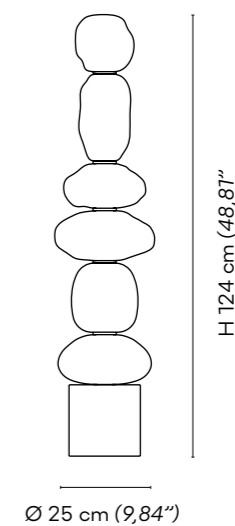

893.86

25 x H 124
6 elementi/ elements
(9,84" - 48,81")

Base: Zimbabwe marmo/ marble

LED

EDIZIONE LIMITATA 8 + 4
LIMITED EDITION 8 + 4





ROTONDO design Peter Marino - 2019

L'opera di Peter Marino è notoriamente provocatoria. Le lampade Rotondo, Cilindro e Parallelo non fanno eccezione: mediante la tecnica delle "Fasce", il maestro cola a caldo, amalgamandoli, dei nastri colorati che avvolgono i volumi geometrici di vetro cristallo, creando dei vortici luminosi dalla bellezza drammatica. Si ottiene così una contrapposizione di grande effetto tra la trasparenza del cristallo e il peso del materiale. Lampada a sospensione in vetro soffiato con struttura in nichel nero lucido.

Peter Marino's work is notoriously provocative. The Rotondo, Cilindro, and Parallelo lamps are no exception: using the "Fasce" technique, the artist hot-works coloured strips wrapped around the geometric volumes of crystal glass, creating luminous vortices of dramatic beauty. A striking contrast is thus obtained between the transparency of the crystal and the weight of the material. Blown glass pendant lamp with glossy black nickel structure.

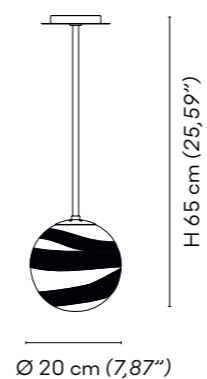

893.50

Caratteristiche tecniche/Technical details:

Ø 20 cm, H 65 cm
1 x max 8W 220 - 240V LED E14
Kg ~5

(7,87" - 25,59")
1 x max 8W 110V LED E12
Lb ~11

Colore /Color

•Cristallo/Te/Nero - Crystal/Tea/Black
•Cristallo/Nero - Crystal/Black

Metallo/Metal

Nichel nero - Black nickel

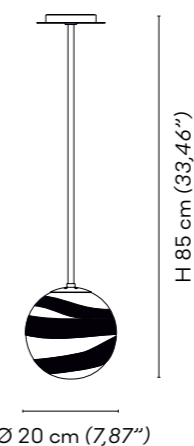

893.51

Caratteristiche tecniche/Technical details:

Ø 20 cm, H 85 cm
1 x max 8W 220 - 240V LED E14
Kg ~5

(7,87" - 33,46")
1 x max 8W 110V LED E12
Lb ~11

Colore /Color

•Cristallo/Te/Nero - Crystal/Tea/Black
•Cristallo/Nero - Crystal/Black

Metallo/Metal

Nichel nero - Black nickel

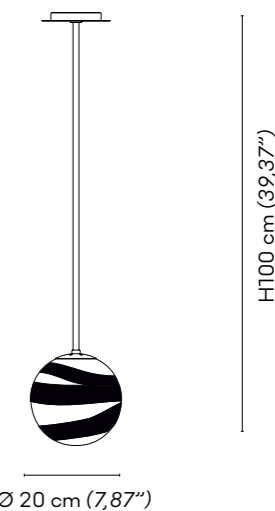

893.52

Caratteristiche tecniche/Technical details:

Ø 20 cm, H 100 cm
1 x max 8W 220 - 240V LED E14
Kg ~5

(7,87" - 39,37")
1 x max 8W 110V LED E12
Lb ~11

Colore /Color

•Cristallo/Te/Nero - Crystal/Tea/Black
•Cristallo/Nero - Crystal/Black

Metallo/Metal

Nichel nero - Black nickel



ROTONDO design Peter Marino - 2019

L'opera di Peter Marino è notoriamente provocatoria. Le lampade Rotondo, Cilindro e Parallelo non fanno eccezione: mediante la tecnica delle "Fasce", il maestro cola a caldo, amalgamandoli, dei nastri colorati che avvolgono i volumi geometrici di vetro cristallo, creando dei vortici luminosi dalla bellezza drammatica. Si ottiene così una contrapposizione di grande effetto tra la trasparenza del cristallo e il peso del materiale. Lampada a sospensione in vetro soffiato con struttura in nichel nero lucido.

Peter Marino's work is notoriously provocative. The Rotondo, Cilindro, and Parallelo lamps are no exception: using the "Fasce" technique, the artist hot-works coloured strips wrapped around the geometric volumes of cristallo glass, creating luminous vortices of dramatic beauty. A striking contrast is thus obtained between the transparency of the cristallo and the weight of the material. Blown glass pendant lamp with glossy black ickel structure

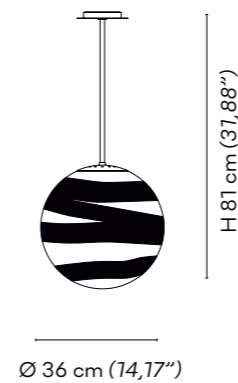

893.55

Caratteristiche tecniche/Technical details:

Ø 36 cm, H 81 cm
1 x max 12W 220 - 240V LED E27
Kg ~11

(14,17" - 31,88")
1 x max 12W 110V LED E26
Lb ~ 24

Colore /Color

Cristallo/Te/Nero - Crystal/Tea/Black
Cristallo/Nero - Crystal/Black

Metallo/Metal

Nichel nero - Black nickel

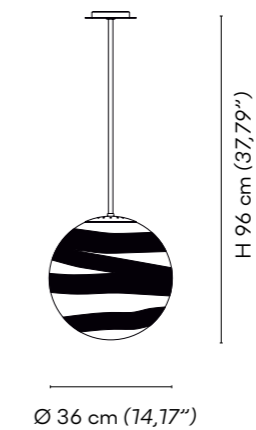

893.56

Caratteristiche tecniche/Technical details:

Ø 36 cm, H 96 cm
1 x max 12W 220 - 240V LED E27
Kg ~11

(14,17" - 37,79")
1 x max 12W 110V LED E26
Lb ~ 24

Colore /Color

Cristallo/Te/Nero - Crystal/Tea/Black
Cristallo/Nero - Crystal/Black

Metallo/Metal

Nichel nero - Black nickel

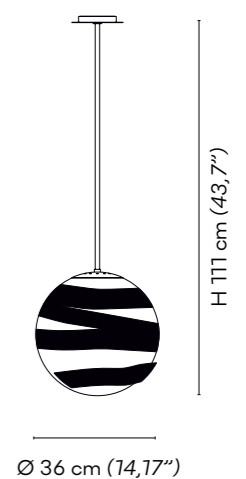

893.57

Caratteristiche tecniche/Technical details:

Ø 36 cm, H 111 cm
1 x max 12W 220 - 240V LED E27
Kg ~11

(14,17" - 43,7")

1 x max 12W 110V LED E26
Lb ~ 24

Colore /Color

Cristallo/Te/Nero - Crystal/Tea/Black
Cristallo/Nero - Crystal/Black

Metallo/Metal

Nichel nero - Black nickel

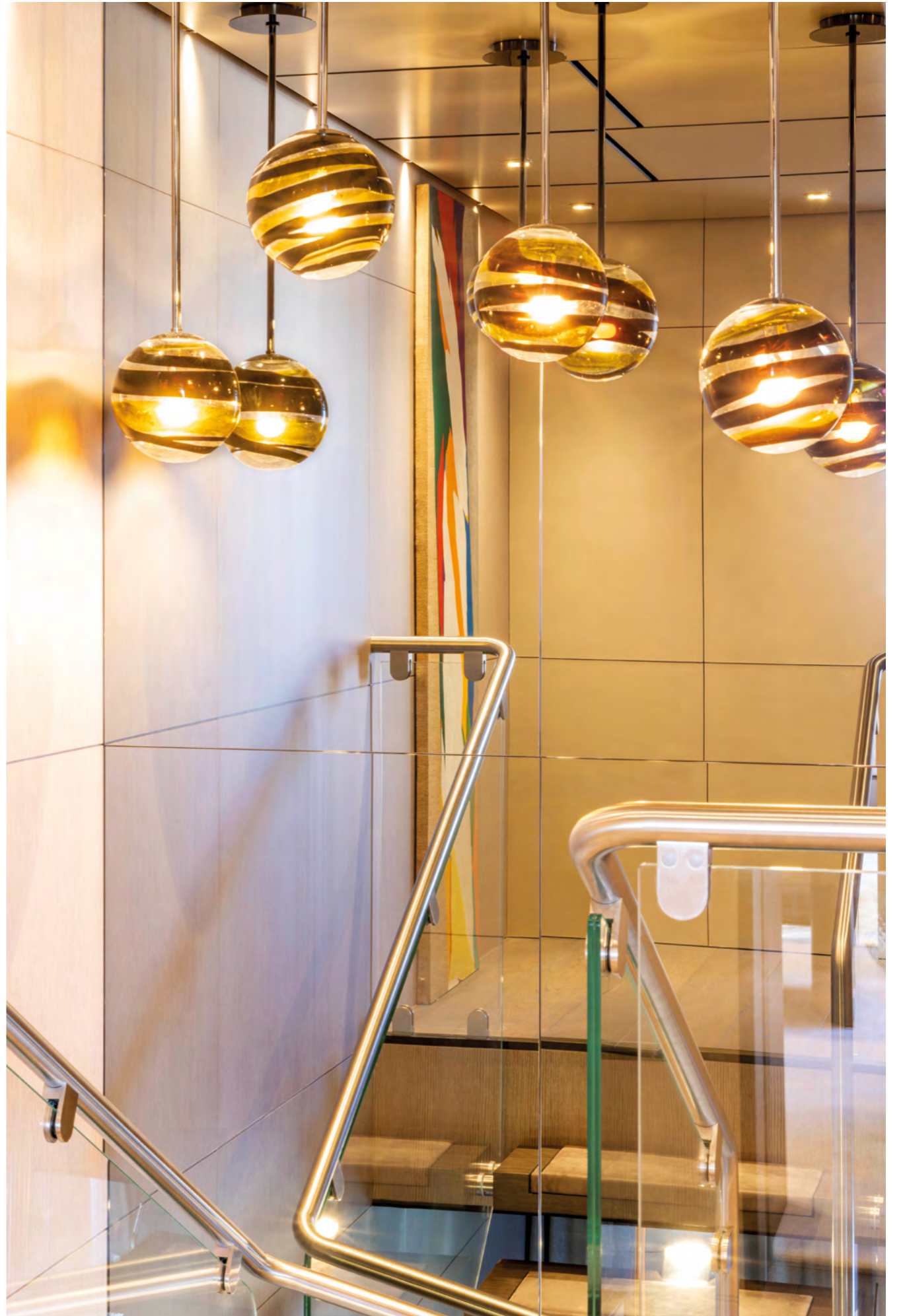

Sospensioni Rotondo su Ferretti Custom Line 140 / Rotondo suspensions lamp on Ferretti Custom Line 140



ROTONDO design Peter Marino - 2019

Lampada a plafone in vetro soffiato, lavorato mediante la tecnica delle "fasce". Struttura realizzata in nichel nero lucido.

Ceiling lamp in blown glass, crafted using the "stripes" technique. Structure made of glossy black nickel.



Ø 20 cm (7,87")

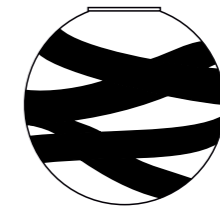

Ø 36 cm (14,17")

893.60

Caratteristiche tecniche/Technical details:

Ø 20 cm
1 x max E14 220 - 240V white 2700K dimmerabile
Kg ~3

(7,87")
1 x max E12 110V - dimmerabile
Lb ~ 6,6

Colore /Color
Cristallo/Te/Nero - Crystal/Tea/Black
Cristallo/Nero - Crystal/Black

Metallo/Metal
Nichel nero - Black nickel

893.61

Caratteristiche tecniche/Technical details:

Ø 36 cm
1 x max E27 220 - 240V white 2700K dimmerabile
Kg ~10

(14,17")
1 x max E26 110V - dimmerabile
Lb ~ 22

Colore /Color
Cristallo/Te/Nero - Crystal/Tea/Black
Cristallo/Nero - Crystal/Black

Metallo/Metal
Nichel nero - Black nickel



CILINDRO design Peter Marino - 2019

Lampada a sospensione in vetro soffiato, lavorata mediante la tecnica delle "fasce". Struttura realizzata in nichel nero lucido.

Blown glass pendant lamp, handcrafted using the "Fasce" technique. Structure made in glossy black nickel.

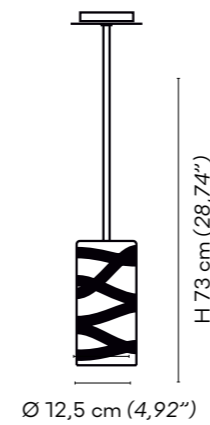

Ø 12,5 cm (4,92")

893.65

**Caratteristiche tecniche/
Technical details:**

Ø 12,5 cm, H max 73 cm
1 x max E14 220 - 240V dimmerabile
Kg ~ 4,6

(4,92" - 28,74")
1 x max E12 110V transparent 2700K
dimmerabile
Lb ~ 10

Colore /Color

Cristallo/Te/Nero - Crystal/Tea/Black
Cristallo/Nero - Crystal/Black

Metallo/Metal

Nichel nero - Black nickel

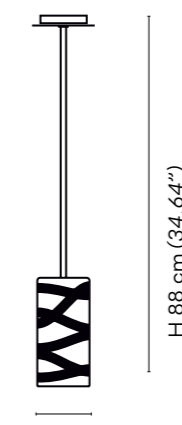

Ø 12,5 cm (4,92")

893.66

**Caratteristiche tecniche/
Technical details:**

Ø 12,5 cm, H max 88 cm
1 x max E27 220 - 240V dimmerabile
Kg ~ 4,6

(4,92" - 34,64")
1 x max E26 110V transparent 2700K
dimmerabile
Lb ~ 10

Colore /Color

Cristallo/Te/Nero - Crystal/Tea/Black
Cristallo/Nero - Crystal/Black

Metallo/Metal

Nichel nero - Black nickel

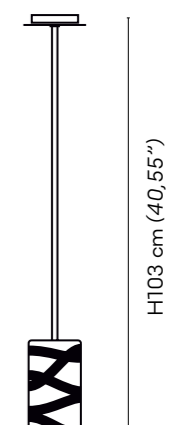

Ø 12,5 cm (4,92")

893.67

**Caratteristiche tecniche/
Technical details:**

Ø 12,5 cm, H max 103 cm
1 x max E27 220 - 240V dimmerabile
Kg ~ 4,6

(4,92" - 40,55")
1 x max E26 110V transparent 2700K
dimmerabile
Lb ~ 10

Colore /Color

Cristallo/Te/Nero - Crystal/Tea/Black
Cristallo/Nero - Crystal/Black

Metallo/Metal

Nichel nero - Black nickel



CILINDRO design Peter Marino - 2019

Lampada a sospensione in vetro soffiato, lavorata mediante la tecnica delle "fasce". Struttura realizzata in nichel nero lucido.

Blown glass pendant lamp, handcrafted using the "Fasce" technique. Structure made in glossy black nickel.

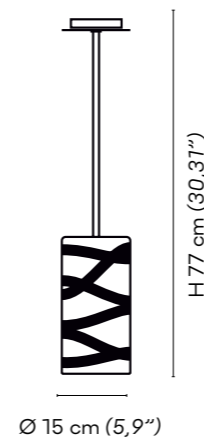

893.70

**Caratteristiche tecniche/
Technical details:**
Ø 15 H max 77 cm
1 x max E14 220 - 240V
Kg ~ 6

(5,9" - 30,31")
1 x max E12 110V transparent 2700K
dimmerabile
Lb ~ 13

Colore /Color
Cristallo/Te/Nero - Crystal/Tea/Black
Cristallo/Nero - Crystal/Black

Metallo/Metal
Nichel nero - Black nickel

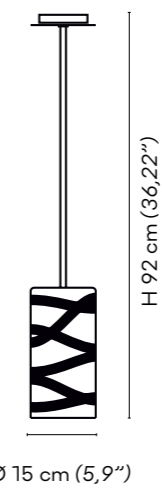

893.71

**Caratteristiche tecniche/
Technical details:**
Ø 15 H max 92 cm
1 x max E27 220 - 240V
Kg ~ 6

(5,9" - 36,22")
1 x max E26 110V transparent 2700K
dimmerabile
Lb ~ 13

Colore /Color
Cristallo/Te/Nero - Crystal/Tea/Black
Cristallo/Nero - Crystal/Black

Metallo/Metal
Nichel nero - Black nickel

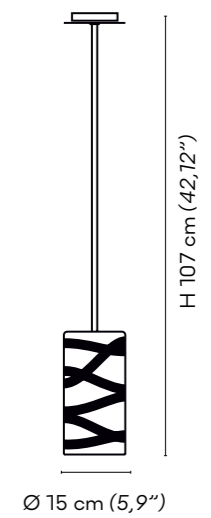

893.72

**Caratteristiche tecniche/
Technical details:**
Ø 15 H max 107 cm
1 x max E27 220 - 240V
Kg ~ 6

(5,9" - 42,12")
1 x max E26 110V transparent 2700K
dimmerabile
Lb ~ 13

Colore /Color
Cristallo/Te/Nero - Crystal/Tea/Black
Cristallo/Nero - Crystal/Black

Metallo/Metal
Nichel nero - Black nickel



PARALLELO design Peter Marino - 2019

Lampada a sospensione in vetro soffiato, a sezione romboidale, lavorato mediante la tecnica delle "fasce". La Struttura è realizzata in nichel nero lucido.

Losenge-shaped blown glass pendant lamp, hand-crafted using the "Fasce" technique. The structure is made in glossy black nickel.

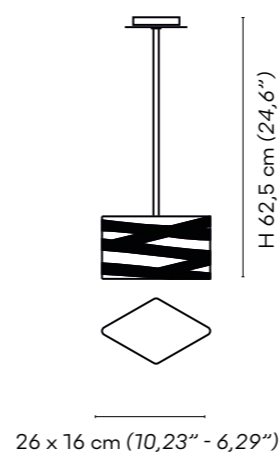

893.75

Caratteristiche tecniche/ Technical details:

26 x 16 H max 62,5 cm
1 x max 220 - 240V E14 dimmerabile
Kg ~ 4

(10,23" x 6,29" - 24,6")
1 x max 110V E12 transparent 2700K
dimmerabile
Lb ~ 8,8

Colore /Color

Cristallo/Te/Nero - Crystal/Tea/Black
Cristallo/Nero - Crystal/Black

Metallo/Metal

Nichel nero - Black nickel

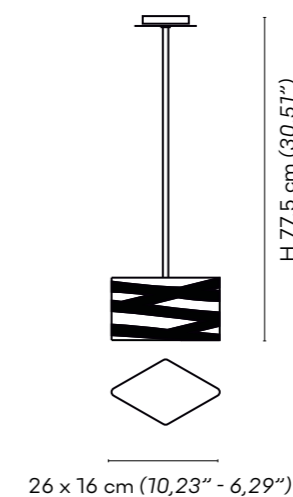

893.76

Caratteristiche tecniche/ Technical details:

26 x 16 H max 77,5 cm
1 x max 220 - 240V E14
Kg ~ 4

(10,23" x 6,29" - 30,24")
1 x max 110V E12 transparent 2700K
dimmerabile
Lb ~ 8,8

Colore /Color

Cristallo/Te/Nero - Crystal/Tea/Black
Cristallo/Nero - Crystal/Black

Metallo/Metal

Nichel nero - Black nickel

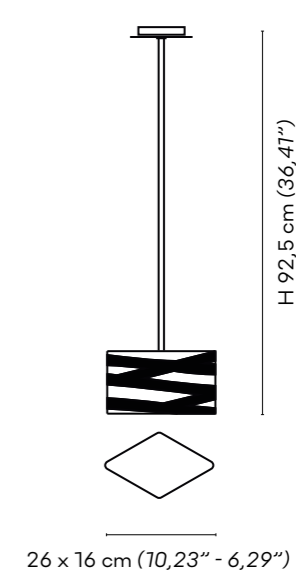

893.77

Caratteristiche tecniche/ Technical details:

26 x 16 H max 92,5 cm
1 x max 220 - 240V E14
Kg ~ 4

(10,23" x 6,29" - 36,4")
1 x max 110V E12 transparent 2700K
dimmerabile
Lb ~ 8,8

Colore /Color

Cristallo/Te/Nero - Crystal/Tea/Black
Cristallo/Nero - Crystal/Black

Metallo/Metal

Nichel nero - Black nickel



PARALLELO design Peter Marino - 2019

Lampada a sospensione in vetro soffiato, a sezione romboidale, lavorata mediante la tecnica delle "fasce". La Struttura è realizzata in nichel nero lucido.

Losenge-shaped blown glass pendant lamp, hand-crafted using the "Fasce" technique. The structure is made in glossy black nickel.

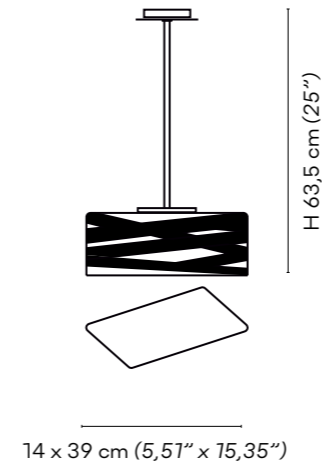

893.80

**Caratteristiche tecniche/
Technical details:**
14 x 39 cm, H max 63,5 cm
1 x max 220 - 240V E14
Kg ~ 8

(5,51" x 15,35" - 25")
2 x max 110V E12 transparent 2700K
dimmerabile
Lb ~ 18

Colore /Color
Cristallo/Te/Nero - Crystal/Tea/Black
Cristallo/Nero - Crystal/Black

Metallo/Metal
Nichel nero - Black nickel

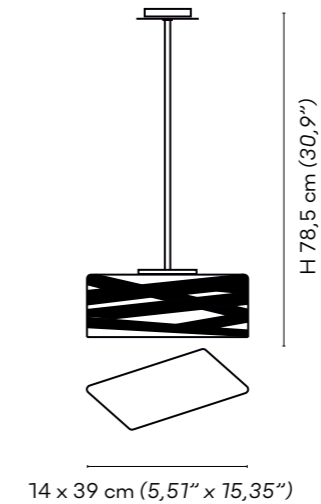

893.81

**Caratteristiche tecniche/
Technical details:**
14 x 39 cm, H max 78,5 cm
1 x max 220 - 240V E14
Kg ~ 8

(5,51" x 15,35" - 30,9")
2 x max 110V E12 transparent 2700K
dimmerabile
Lb ~ 18

Colore /Color
Cristallo/Te/Nero - Crystal/Tea/Black
Cristallo/Nero - Crystal/Black

Metallo/Metal
Nichel nero - Black nickel

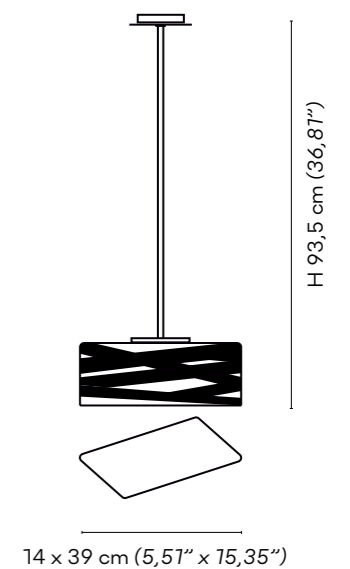

893.82

**Caratteristiche tecniche/
Technical details:**
14 x 39 cm, H max 93,5 cm
1 x max 220 - 240V E14
Kg ~ 8

(5,51" x 15,35" - 36,8")
2 x max 110V E12 transparent 2700K
dimmerabile
Lb ~ 18

Colore /Color
Cristallo/Te/Nero - Crystal/Tea/Black
Cristallo/Nero - Crystal/Black

Metallo/Metal
Nichel nero - Black nickel

ARTGLASS



GRAN BULBO Mini design by Peter Marino - 2023

Il nuovo vaso-scultura GRAN BULBO di Peter Marino è una sintesi dell'abilità dei maestri vetrai e di un sapere secolare, interamente lavorato a mano con la tecnica del vetro soffiato. Il vaso è disponibile in color cristallo con fasce di vetro nella nuance verde, impreziosito con finiture smaltate in oro e argento e in versione cristallo con foglia oro e fasce té con decori oro.

The new version of the sculpture-vase, GRAN BULBO by Peter Marino, is a synthesis of the skill of master glassblowers and centuries-old knowledge, entirely handcrafted with the blown glass technique. The vase is available in crystal color with glass bands in green shades, adorned with enameled gold and silver finishes, and in crystal version with gold leaf and tea-colored bands with gold decorations.

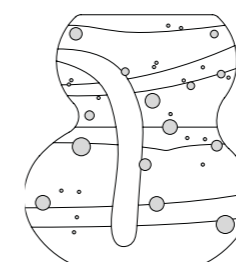

699.61

18,3 x 27,8 cm, H 25 cm
Kg. ~ 20

(7,2" x 10,94" - 9,84")
Lb ~ 44

Cristallo/ fasce Verde Mela/decoro Oro
Cristallo/ fasce Verde Mela-lattimo/decoro Oro
Cristallo/ fasce Verde Mela/decoro argento
Cristallo/ fasce Verde Mela-lattimo/decoro Argento
Cristallo/Foglia Oro - fasce Té/decoro Oro

*Crystal /Apple Green/Gold decoration
Crystal/Apple Green- Milk-White/Gold decoration
Crystal /Apple Green/with Silver decoration
Crystal/Apple Green- Milk-White/Silver decoration
Crystal-Gold leaf / Tea bands/Gold decoration*

**EDIZIONE LIMITATA IN 349 OPERE
LIMITED EDITION OF 349 ARTWORKS**



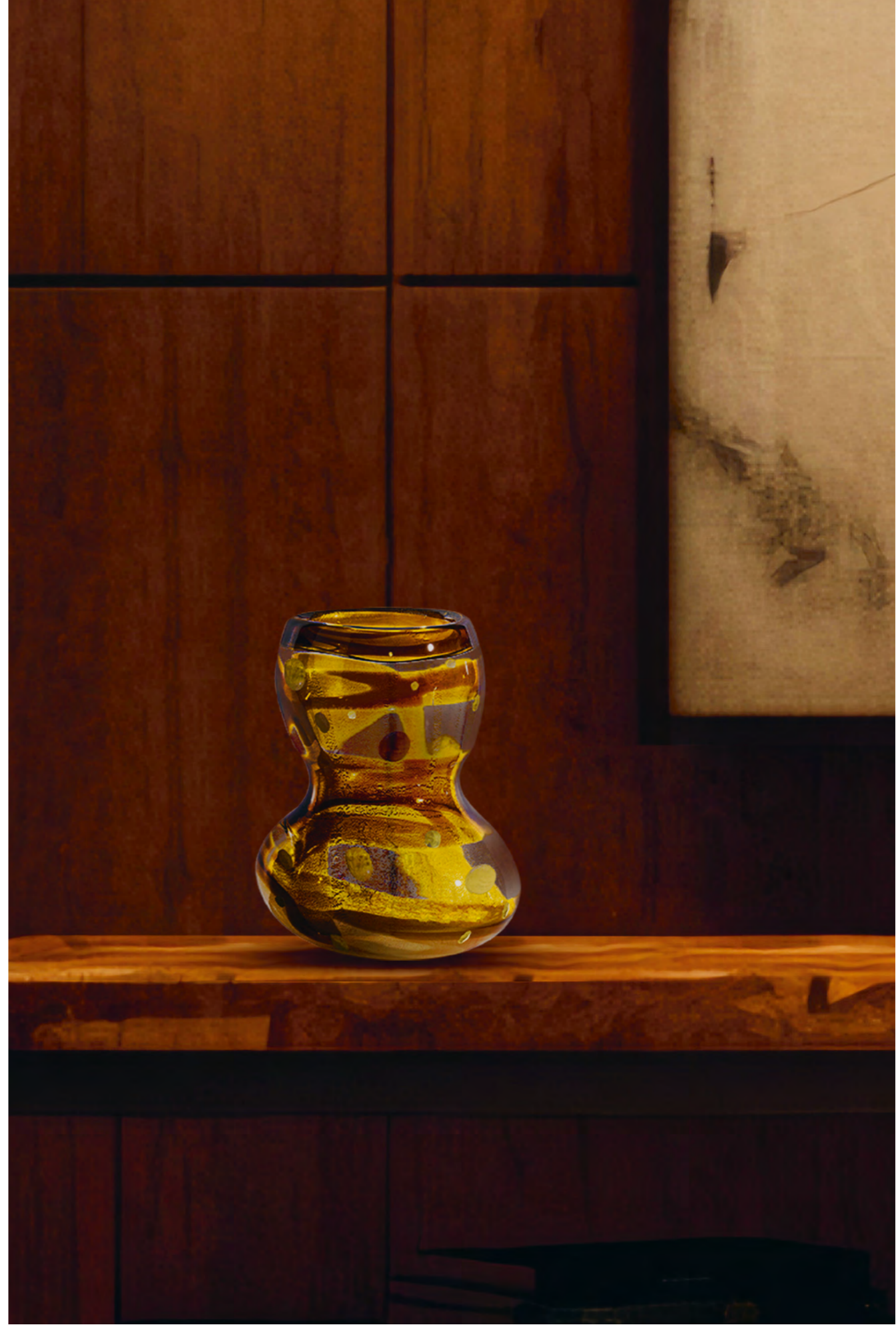



CILINDRO design by Peter Marino - 2023

I nuovi vasi CILINDRO soffiati e lavorati a mano in vetro color cristallo segnano un tratto distintivo forte, ossia le fasce nere sommerse che ne accentuano la forma e la presenza scenica.

La collezione in edizione limitata è disponibile nelle altezze 14 e 40 centimetri.

The new hand-blown and hand-crafted CILINDRO vases in the Cristallo glass shade stand out for a distinctive bold feature, the black bands created using the sommerso technique, accentuating form and scenic presence. The limited edition collection is available in heights of 14 and 40 centimeters.



699.54

Ø 20 cm, H 40 cm
(7,87" - 15,74")

Cristallo/ fasce Nero
Crystal/Black bands



699.55

Ø 30 cm, H 14 cm
(11,81" - 5,51")

Cristallo/ fasce Nero
Crystal/Black bands

**EDIZIONE LIMITATA IN 349 OPERE
LIMITED EDITION OF 349 ARTWORKS**



CILINDRO design by Peter Marino - 2023

La nuova variante cromatica della collezione Cilindro presenta strisce opaline Verde Mela che circondano il vaso, creando un elegante contrasto con il vetro color cristallo. La superficie è ornata da decori smaltati in Oro e Argento. Questa edizione limitata diventa elegantemente un elemento centrale in ogni spazio.

The new chromatic variant of the Cilindro collection features opaline Apple Green stripes that surround the vase, creating an elegant contrast with the crystal-colored glass. The surface is adorned with enameled Gold and Silver decorations. This limited edition elegantly becomes a central element in any space.



699.50

Ø 8 cm, H 15 cm
(3,14" - 5,9")

Cristallo/ fasce Nere
Cristallo/fasce Verde
Mela - Lattimo
Cristallo-Foglia Oro/
fasce Té

Crystal/Black bands
Crystal/Apple Green-
Milk white bands
Crystal-Gold Leaf/
Tea bands



699.51

Ø 10 cm, H 18 cm
(3,93" - 7,08")

Cristallo/ fasce Nere
Cristallo/fasce Verde
Mela - Lattimo
Cristallo-Foglia Oro/
fasce Té

Crystal/Black bands
Crystal/Apple Green-
Milk white bands
Crystal-Gold Leaf/
Tea bands



699.52

Ø 13 cm, H 25 cm
(5,11" - 9,84")

Cristallo/ fasce Nere
Cristallo/fasce Verde
Mela - Lattimo
Cristallo-Foglia Oro/
fasce Té

Crystal/Black bands
Crystal/Apple Green-
Milk white bands
Crystal-Gold Leaf/
Tea bands



699.53

Ø 16 cm, H 32 cm
(6,29" - 12,59")

Cristallo/ fasce Nere
Cristallo/fasce Verde
Mela - Lattimo
Cristallo-Foglia Oro/
fasce Té

Crystal/Black bands
Crystal/Apple Green-
Milk white bands
Crystal-Gold Leaf/Tea
bands



699.54

Ø 20 cm, H 40 cm
(7,87" - 15,75")

Cristallo/ fasce Nere
Cristallo/fasce Verde
Mela - Lattimo
Cristallo-Foglia Oro/
fasce Té

Crystal/Black bands
Crystal/Apple Green-
Milk white bands
Crystal-Gold Leaf/
Tea bands

EDIZIONE LIMITATA IN 349 OPERE/LIMITED EDITION OF 349 ARTWORKS









TOTEM

design by Peter Marino - 2022

TOTEM, una linea che enfatizza la potenza evocativa delle decorazioni tribali in un oggetto scultoreo. L'opera è frutto della combinazione tra la solidità di una base in marmo nero Zimbabwe eleganti elementi in vetro soffiato dalle forme morbide e dai rimandi organici.

Un tributo alla natura impreziosito da lavorazioni a caldo con la foglia d'argento, d'oro e di superfici dall'effetto iridato. La scultura, in edizione limitata, è disponibile in due misure ed è proposta anche nella versione illuminata.

TOTEM, collection that emphasizes the evocative power of tribal decorations on a sculptural object. The work is the result of the combination of the solidity of a black Zimbabwe marble base and elegant blown glass elements with soft shapes and organic references.

A tribute to nature embellished with hot handmade technique with silver and gold leaf and surfaces with iridescent effect.

The limited-edition sculpture is available in two sizes and is also proposed in the luminous version.

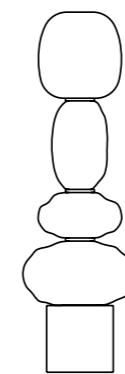

699.40

25 x H 81 cm
4 elementi/ elements
(9,84" - 31,88")

EDIZIONE LIMITATA - LIMITED EDITION
8 + 4

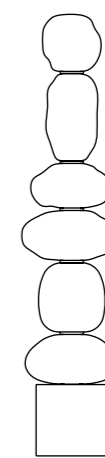

699.41

25 x H 124 cm
6 elementi/ elements
(9,84" - 48,81")

EDIZIONE LIMITATA - LIMITED EDITION
8 + 4



GRAN BULBO design by Peter Marino - 2022

Il vaso-scultura GRAN BULBO di Peter Marino sintetizza nei suoi 50 centimetri di altezza l'abilità dei maestri vetrai e un sapere secolare, grazie alla sua natura artigianale e maestosa.

Lavorato interamente a mano con la tecnica del vetro soffiato, è proposto nella versione color cristallo con inclusioni di fasce di vetro nella nuance Tè impreziosito di foglia d'oro.

In its 50 centimetres of height, Peter Marino's GRAN BULBO sculpture vase sums up the master glassmakers' skill and centuries-old know-how, thanks to its qualities of fine craftsmanship and splendour. Entirely handcrafted using the blown glass technique, it is proposed in the Cristallo glass version with Tea-coloured glass bands decorated with gold leaf.

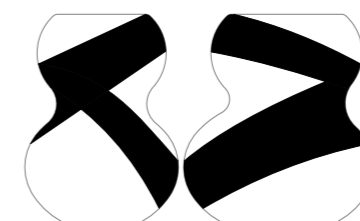

699.60

38 x 31 cm, H 50 cm
Kg: ~ 20

(14,96" x 12,2" - 19,68")
Lb ~ 44

Cristallo/ fasce Tè con foglia oro
Cristallo/ fasce Nere

*Crystal/Tea bands with gold leaf
Crystal/Black bands*

EDIZIONE LIMITATA - LIMITED EDITION
8 + 4





BLACK BELT' - Otto design by Peter Marino - 2017

“ La forza della luce e della materia sono elementi fondamentali per tutti i miei progetti architettonici. La collezione di vasi Black Belt ha origine da queste considerazioni. L'artigianalità del vetro, caratteristica di Venini, nasce nel 13° secolo. Ancora oggi questo processo di lavorazione permette ai designer di realizzare concetti completamente moderni come queste particolari opere d'arte.”

“The power of light and materiality are paramount to all my architectural projects - the Black Belt collection of vases evolved from these considerations. The craftsmanship of Venini dates to the 13th century, yet the process allows for designers to realize entirely modern concepts such as these individual works of art.”

Peter Marino
2017



699.10 Otto Medium
18 x 10 H 20 cm
(7" - 3,93" - 7,87")

Cristallo/Rosato fasce Nere
Cristallo/Verde erba fasce Nere

*Crystal/Rose Black decoration
Crystal/Grass Green Black decoration*



699.13 Otto Large
28 x 11 H 29 cm
(11" - 4,33" - 11,41")

Cristallo/Rosato fasce Nere
Cristallo/Verde Erba fasce Nere

*Crystal/Rose Black decoration
Crystal/Grass Green Black decoration*

EDIZIONE LIMITATA IN 349 OPERE/LIMITED EDITION OF 349 ARTWORKS





BLACK BELT - Ovale design by Peter Marino - 2017

“ La forza della luce e della materia sono elementi fondamentali per tutti i miei progetti architettonici. La collezione di vasi Black Belt ha origine da queste considerazioni. L'artigianalità del vetro, caratteristica di Venini, nasce nel 13° secolo. Ancora oggi questo processo di lavorazione permette ai designer di realizzare concetti completamente moderni come queste particolari opere d'arte.”

“The power of light and materiality are paramount to all my architectural projects - the Black Belt collection of vases evolved from these considerations.

The craftsmanship of Venini dates to the 13th century, yet the process allows for designers to realize entirely modern concepts such as these individual works of art.”

Peter Marino
2017



699.20 Ovale X-Small
12 x 11 H 12 cm
(4,72" x 4,33" - 4,72")

Cristallo/Verde Erba fasce
Nere
Crystal / Grass Green Black
decoration



699.21 Ovale Small
18 x 16,5 H 18 cm
(7" x 6,49" - 7")

Cristallo/Verde Erba fasce
Nere
Crystal / Grass Green Black
decoration



699.22 Ovale Medium
22 x 16 H 24 cm
(8,66" x 6,29" - 9,44")

Cristallo/Verde Erba fasce
Nere
Crystal / Grass Green Black
decoration



699.23 Ovale Large
29 x 20 H 29 cm
(11,41" - 7,87" - 11,41")

Cristallo/Verde Erba fasce
Nere
Crystal / Grass Green Black
decoration

EDIZIONE LIMITATA IN 349 OPERE/LIMITED EDITION OF 349 ARTWORKS



BLACK BELT - Triangolo design by Peter Marino - 2017

“La forza della luce e della materia sono elementi fondamentali per tutti i miei progetti architettonici. La collezione di vasi Black Belt ha origine da queste considerazioni.

L’artigianalità del vetro, caratteristica di Venini, nasce nel 13° secolo. Ancora oggi questo processo di lavorazione permette ai designer di realizzare concetti completamente moderni come queste particolari opere d’arte.”

“The power of light and materiality are paramount to all my architectural projects - the Black Belt collection of vases evolved from these considerations.

The craftsmanship of Venini dates to the 13th century, yet the process allows for designers to realize entirely modern concepts such as these individual works of art.”

Peter Marino
2017



699.15 Triangolo

L. 9,5 cm; Ø 9,5cm; H 11 cm
(3,7"-3,7"- 4,33")

Kg: ~ 1
Cristallo/ Tè fasce Nere
Crystal / Tea Black decoration



699.16 Triangolo

L. 12cm; Ø 12cm; H 16,5 cm
(4,72"- 4,72"-6,49")

Kg: ~ 4
Cristallo/ Tè fasce Nere
Crystal / Tea Black decoration



699.17 Triangolo

L. 14,5 cm; Ø 14,5 cm H 20 cm
(5,7" - 5,7" - 7,87")

Kg: ~ 4
Cristallo fasce Nere
Crystal Black decoration



699.18 Triangolo

L. 18 cm; Ø 18 cm; H 29 cm
(7"- 7"-11,41")

Kg: ~ 8
Cristallo/ Tè fasce Nere
Crystal / Tea Black decoration

EDIZIONE LIMITATA IN 349 OPERE/LIMITED EDITION OF 349 ARTWORKS





BLACK BELT - Quadro design by Peter Marino - 2017

“La forza della luce e della materia sono elementi fondamentali per tutti i miei progetti architettonici. La collezione di vasi Black Belt ha origine da queste considerazioni.

L'artigianalità del vetro, caratteristica di Venini, nasce nel 13° secolo. Ancora oggi questo processo di lavorazione permette ai designer di realizzare concetti completamente moderni come queste particolari opere d'arte.”

“The power of light and materiality are paramount to all my architectural projects - the Black Belt collection of vases evolved from these considerations.

The craftsmanship of Venini dates to the 13th century, yet the process allows for designers to realize entirely modern concepts such as these individual works of art.”

Peter Marino
2017



699.30 Quadro
12 x 12 H 15 cm
(4,72" - 4,72" - 5,9")

Cristallo fasce Nere
Crystal Black decoration

EDIZIONE LIMITATA IN 349 OPERE
LIMITED EDITION OF 349 ARTWORKS



BLACK BELT - Glasses design by Peter Marino - 2024

I nuovi bicchieri disegnati da Peter Marino si ispirano al suo stile grintoso ed inconfondibile.

Ogni bicchiere è un'opera d'arte unica, caratterizzata da fasce nere applicate a caldo con maestria artigianale, che si intrecciano in quattro design distinti. Prendendo spunto dallo stile accattivante e dalla personalità vibrante del designer americano, questi bicchieri trasportano con sé un'energia unica, che celebra l'arte e la bellezza rendendoli perfetti per ogni mise en place.

The new glasses designed by Peter Marino are inspired by his bold and distinctive style.

Each glass is a unique work of art, characterized by black bands applied hot with skilled craftsmanship, which intertwine in four distinct designs.

Taking cues from the designer's captivating style and vibrant personality, these glasses carry a unique energy that celebrates art and beauty, making them perfect for any table setting.



303.00

Ø 8 x H 11 cm
(3,15" - 4,33")

Cristallo fasce Nere
Crystal Black decoration





RED BELT - Centerpiece design by Peter Marino - 2024

I nuovi centrotavola disegnati da Peter Marino si aggiungono alla celebre collezione Black Belt, portando con sé una nuova colorazione. Il vetro color cristallo prende vita sotto l'abile maestria degli artigiani, decorato da fasce di vetro rosso, applicate a caldo, che abbracciano delicatamente ogni centrotavola, creando un motivo incrociato che è un tributo al design unico del rinomato designer americano.

Come tocco finale, eleganti ornamenti dorati impreziosiscono questi piatti, disponibili in due misure, aggiungendo una nota raffinata che li rende ancora più esclusivi.

The new centerpieces designed by Peter Marino add to the famous Black Belt collection, bringing with them a new coloration. The crystal glass comes to life under the skilled mastery of the artisans, decorated with hot-applied stripes of red glass, which delicately embrace each centerpiece, creating an intersecting pattern that is a tribute to the unique design of the renowned American designer.

As a finishing touch, elegant golden ornaments embellish these dishes, available in two sizes, adding a refined note that makes them even more exclusive.

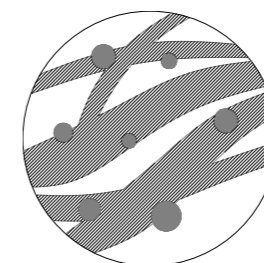

699.70
Ø 35cm x H 8cm (13,8" x 3,1")

Cristallo fasce Rosse/ decori Oro
Crystal, Red bands/ Gold decoration

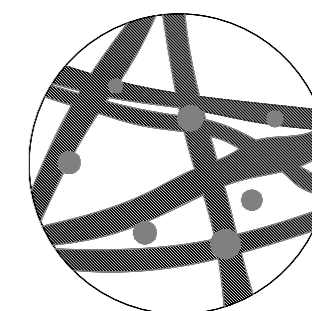

699.71
Ø 45cm (17,7" x 3,1")

Cristallo fasce Rosse/ decori Oro
Crystal, Red bands/ Gold decoration

EDIZIONE LIMITATA IN 349 OPERE
LIMITED EDITION OF 349 ARTWORKS





Concept and project:
VENINI S.p.A.

Photo:
Archivio Fotografico Venini
Lucrezia Roda

Disegni storici - historical drawings:
MUSEO VENINI
(45.000 disegni d'autore)
(45.000 author drawings)

copyright notice
Il presente catalogo è tutelato dalla legge sui diritti d'autore di esso è quindi proibita ogni riproduzione, totale o anche parziale. Qualora venga concessa la preventiva autorizzazione alla riproduzione è d'obbligo citarne la fonte.

copyright notice
No part of this catalogue may be reproduced in any form or by any means. When prior authorisation for reproduction has been given, the source must be clearly stated.

VENINI - PETER MARINO - ARTGLASS & ARTLIGHT
October 2024

L'unicità della produzione VENINI è data dai procedimenti artigianali seguiti per tutte le fasi della lavorazione.
Ogni Opera è realizzata a mano, si possono quindi riscontrare alcune sfumature di colore, bollicine o dettagli produttivi che sono la caratteristica dell'originalità.

*The uniqueness of VENINI's production is given by handcraft procedures followed during all working processes.
Some shades or bubbles, that might be found on the glass, underline that every single piece is entirely handmade and even if similar to the others, each single piece is unique.*

Follow VENINI at:

www.venini.com



VENINI

Venini S.p.A. Fondamenta Vetrai, 50 - 30141 Murano Venezia - Italia - venini@venini.com



Made in Italy